

8 7 6 5 4 3 2 1

D

C

B

A

D

C

B

A

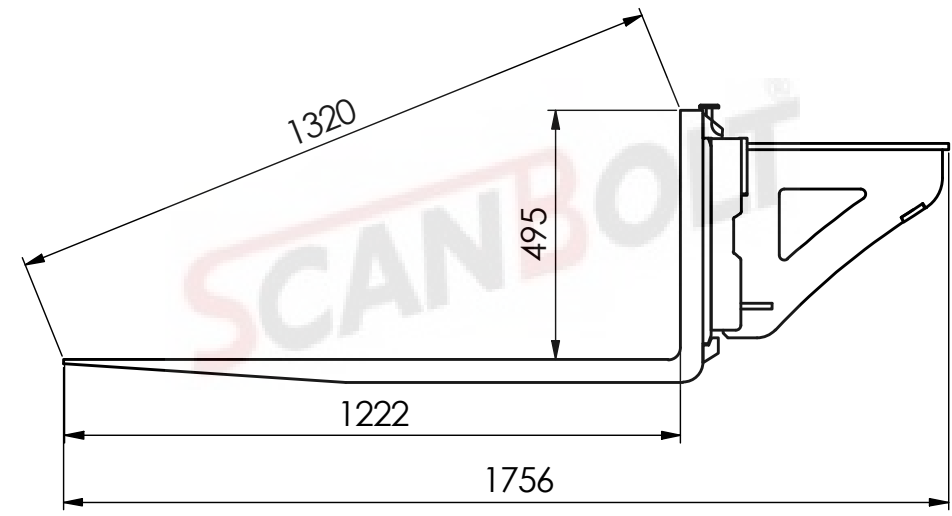
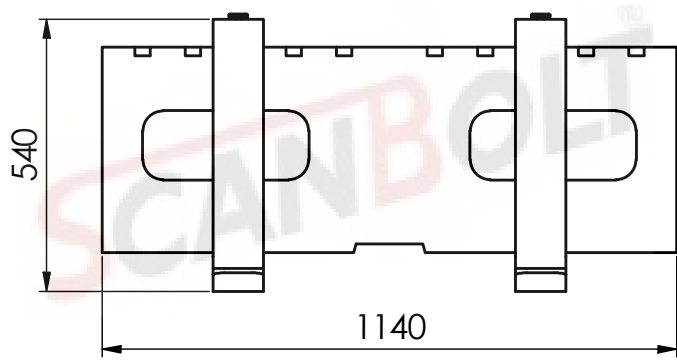
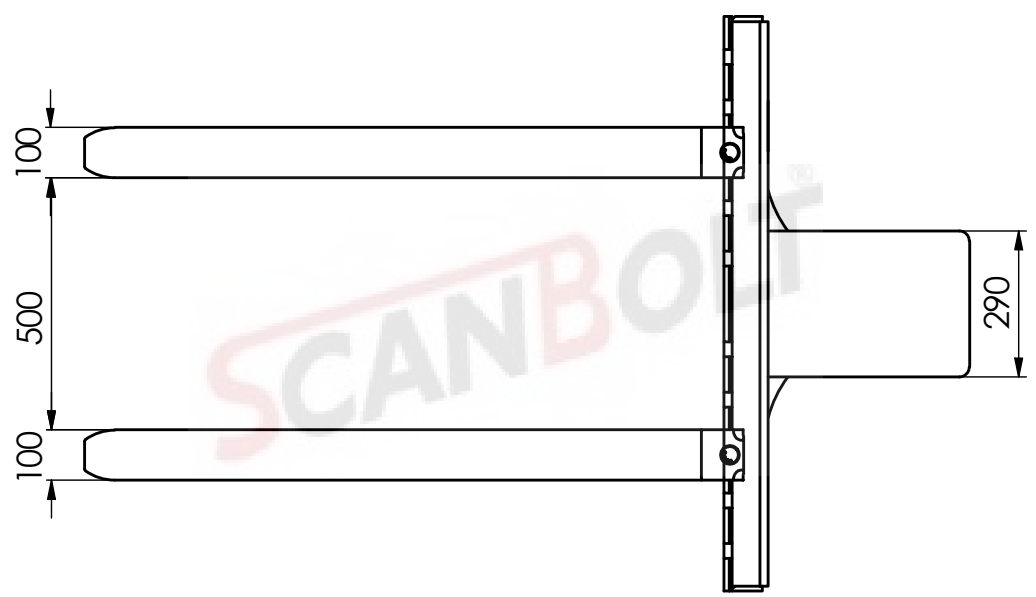
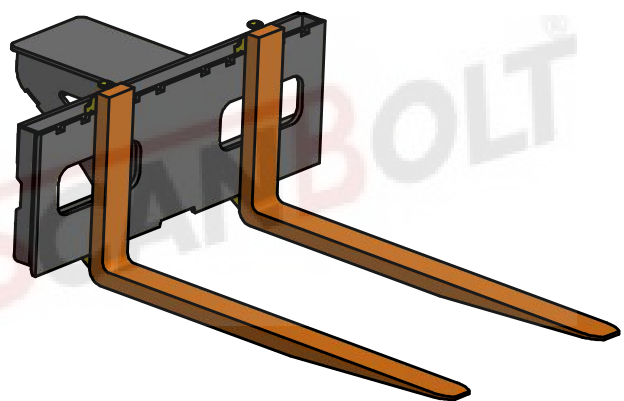

MATERIAL SPECIFICATION	
ST52.3	Grey
EN8D	Pink
HB 400	Light Orange
HB 450	Dark Orange
CASTALLOY STEEL	Yellow

SCANBOLT®	
DESCRIPTION	PALLET FRAME WITH FORK
MACHINE CLASS	1.3-3.4 TON
WEIGHT	229.13 KG
HEAPED CAPACITY	

8 7 6 5 4 3 2 1